

OPERATING INSTRUCTIONS

DCD Design & Manufacturing Ltd. SERIES 00503 DUB-LITE® STYLE 2



OPERATION

1. Remove the socket head cap screws and lock washers from the clevis pin nuts.
2. Unscrew the clevis pin nuts from the clevis pins and remove the clevis pins from the swivel.
3. Insert the items you want to attach into the clevis ends. Re assemble the clevis pins and nuts.

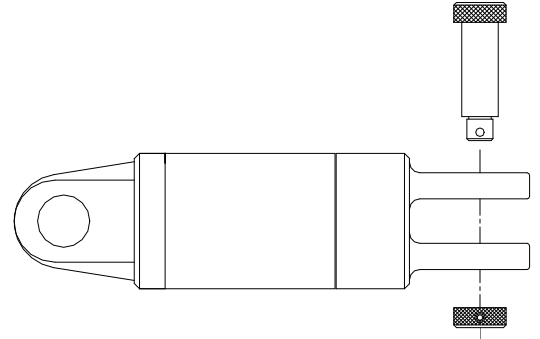

SAFETY

The DUB-LITE® Swivel is designed to operate only within its specified safe working limit (see *Operating Specifications*). Operation of the DUB-LITE® Swivel at loads in excess of its **safe working limit** will void the warranty as that may cause permanent bearing damage even though separation due to failure will not occur until the specified **ultimate load** is reached.



Rotating parts can cause death or serious injury! Stay well clear. Do not wear loose clothing.



A swivel is not a universal joint! It is designed to be used under tension and in a straight line. Any use of this product that allows the swivel to fall away from the centerline of rotation will severely affect the life of the swivel.

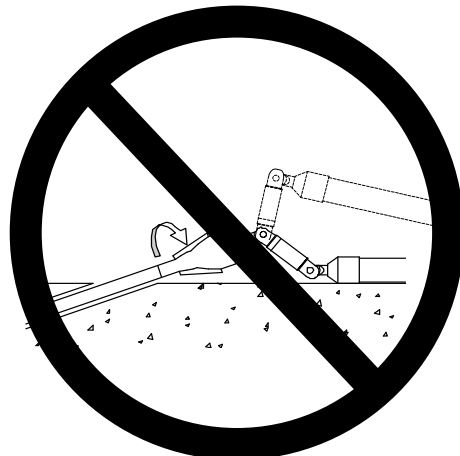

SAFETY – continued

Use the following procedure for attaching the swivel to the reamer. This procedure will ensure maximum safety for personnel in the area of operation and avoid unnecessary side loads on the swivel which may cause permanent damage.

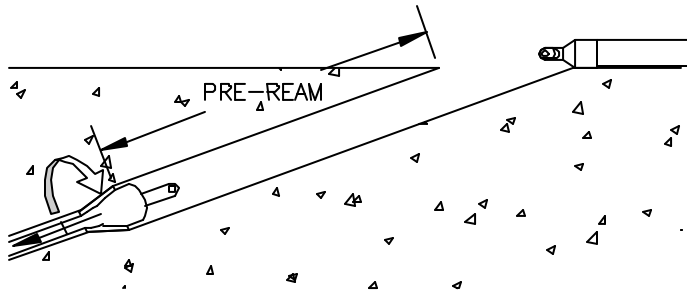

Step 1 Pre-ream hole to minimum of one drill rod length.

Step 2 Push reamer back to surface. Attach Swivel and Duct Puller to reamer.

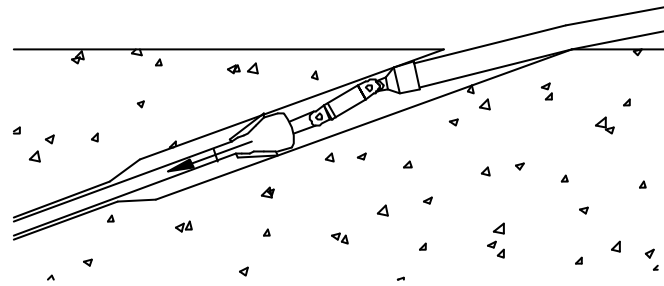

Step 3 Pull back without rotation for the length of the pre-reamed hole.

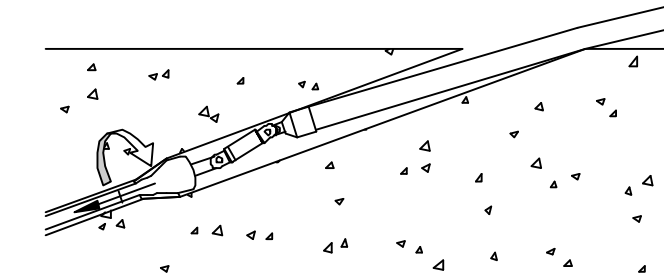

Step 4 Start rotation slowly and continue pullback.



Make sure that all components of the pulling system are able to withstand the maximum pulling loads. Components not rated for the pull force may break and release the stored energy of the pull. Never use a worn, defective or incomplete component.



Be prepared for the unexpected. Always use recognized safety practices and wear recognized safety equipment.



Do not modify or dismantle the DUB-LITE® Swivel. It has been assembled, and inspected and is only covered by a warranty in its "as shipped" form. Any attempt to dismantle or modify the swivel will result in the warranty becoming void.



Replace worn or damaged Clevis Pins with only DCD parts. The Clevis Pin is designed specifically for this application. It is manufactured and heat treated in a manner to satisfy both design requirements and claimed capacities. Use of any other product as a replacement part will void the warranty and may result in property damage, severe bodily harm, or death to operators or persons nearby. In any instances, the DCD warranty will be voided and DCD will accept no responsibility for product failure or personal injury.

OPERATING INSTRUCTIONS

SERVICE



After each use, while the machine is still rotating, use a water hose to wash all dirt from the split line groove. Pour oil into the groove and rotate the swivel a couple of turns to protect the seals from drying out. Failure to do so will allow mud to dry inside the cavity above the seals, which may damage the rubber portion of the seals.



Assess the condition of the swivel checking for wear and external damage. Check for axial and radial play in the bearings. Replace worn or bent Clevis Pins.



Lubricate the swivel with a **lithium-based grease** containing an extreme pressure (EP) additive (the swivel has been factory lubricated with **Renolit S2TX** grease). Do not mix with calcium or other based greases. Use a hand-operated grease gun with slow pumping action. Lack of proper lubrication will shorten the life of the bearings. Note the grease will disperse from the split line between the Swivel Body and Swivel Head.



A replacement kit is available for the DUB-LITE® Swivel Clevis Pins. Each kit contains (2) clevis pins, (2) clevis pin nuts, (2) lockwashers, and (2) capscrews. The kit part number is 00508-0XX. For other spare parts, contact your dealer for price and availability. Never use standard Hex Bolts as replacement for the DCD Clevis Pins.



A replacement part kit containing bearings and seals is available for the DUB-LITE® Swivel. Replacement of parts should only be done using this kit and must be installed as per instructions included with the kit. Use of this kit will not extend product warranty unless factory installed. Call the factory toll free at **1-888-794-8357** for factory rebuild service.

