

***DIGITRAK*[®] FCD**

**Falcon Compact Display for HDD
Guidance System**

Operator's Manual

403-4210-00-B, English, printed on 1/9/2019

© 2019 Digital Control Incorporated. All rights reserved.

Patents

U.S. and foreign patents apply to the product covered by this manual. For details, please visit digital-control.com.

Limited Warranty

All products manufactured and sold by Digital Control Incorporated (DCI) are subject to the terms of a Limited Warranty. A copy of the Limited Warranty is included at the end of this manual; it can also be obtained at digital-control.com.

Important Notice

All statements, technical information, and recommendations related to DCI products are based on information believed to be reliable. However, DCI does not warrant or guarantee the accuracy or completeness of such information. Before using any DCI product, the user should determine the suitability of the product for its intended use. All statements herein refer to DCI products as delivered by DCI for use with horizontal directional drilling in the ordinary course, and do not apply to any user customizations, third-party products, or any usage of the DCI product outside of the ordinary course. Nothing herein shall constitute a warranty by DCI nor will anything herein be deemed to modify the terms of DCI's existing Limited Warranty applicable to all DCI products. DCI may update or correct the information in this manual from time to time. You may find the most recent version of this manual on DCI's website, digital-control.com.

Compliance Statement

This equipment complies with Part 15 of the Rules of the FCC and with Industry Canada license-exempt RSS standards and with Australia Class License 2000 for LIPD (low interference potential devices). Operation is subject to the following two conditions: (1) this equipment may not cause harmful interference, and (2) this equipment must accept any interference received, including interference that may cause undesired operation. DCI is responsible for FCC compliance in the United States: Digital Control Incorporated, 19625 62nd Ave S, Suite B103, Kent WA 98032; phone 425.251.0559 or 800.288.3610 (US/CA).

Changes or modifications to any DCI equipment not expressly approved and carried out by DCI will void the user's Limited Warranty and the FCC's authorization to operate the equipment.

CE Requirements: Telemetry Use Restrictions

DigiTrak receivers may not be legal to operate or may require a user license to operate in some countries. The complete table and declarations of conformity are available at digital-control.com.

Contact Us

United States
DCI Headquarters

19625 62nd Ave S, Suite B103
Kent, Washington 98032, USA
1.425.251.0559 / 1.800.288.3610
1.425.251.0702 fax
dcidigital-control.com

Australia

2/9 Frinton Street
Southport QLD 4215
61.7.5531.4283
61.7.5531.2617 fax
dciaustralia@digital-control.com

China

368 Xingle Road
Huacao Town
Minhang District
Shanghai 201107, P.R.C.
86.21.6432.5186
86.21.6432.5187 (传真)
dcichina@digital-control.com

Europe

Brueckenstraße 2
97828 Marktheidenfeld
Deutschland
49.9391.810.6100
49.9391.810.6109 Fax
dcieurope@digital-control.com

India

DTJ 203, DLF Tower B
Jasola District Center
New Delhi 110025
91.11.4507.0444
91.11.4507.0440 fax
dcindia@digital-control.com

Russia

Молодогвардейская ул., д.4
стр. 1, офис 5
Москва, Российская Федерация 121467
7.499.281.8177
7.499.281.8166 факс
dcirusssia@digital-control.com

Dear Customer,

Thank you for choosing a DigiTrak guidance system. We are proud of the equipment we have been designing and building in Washington State since 1990. We believe in providing a unique, high-quality product and standing behind it with world-class customer service and training.

Please take the time to read this entire manual, especially the section on safety. Please also register your equipment online at www.MyDigiTrak.com. Or, fill in the product registration card provided with this equipment and either fax it to us at 253-395-2800 or mail it to DCI headquarters.

Product registration entitles you to free telephone support (in the USA and Canada), notification of product updates, and helps us provide you with future product upgrade information.

Our Customer Service department is available 24 hours a day, 7 days a week in the U.S. to help with problems or questions. International contact information is available in this document and on our website.

As the horizontal directional drilling industry grows, we're keeping our eye on the future to develop equipment that makes your job faster, easier, and safer. Visit us online any time to see what we're up to.

We welcome your questions, comments, and ideas.

Digital Control Incorporated
Kent, Washington
2019

Watch our DigiTrak Training Videos at www.YouTube.com/DCIKent

For system component name and model information, refer to [Appendix A: System Specifications](#) on page 12.

Table of Contents

- Important Safety Instructions** 1
- Introduction** 1
- Overview** 2
 - General Description 2
 - Installing and Removing the Battery Pack 2
 - Push Button 3
 - Audible Tones 3
 - Adjusting the Viewing Angle 3
- Main Menu** 4
 - Remote Mode 4
 - Power On/Off 4
 - Settings 5
 - Contrast Adjustment 5
 - System Information 6
- Display Screens** 6
 - Remote Mode Locating Screen 6
 - Depth Screen 7
 - Predicted Depth Screen 8
- Remote Steering** 9
 - Steering to the Target 9
 - Remote Steering in Interference Areas 11
 - Turning Remote Steering Off 11
- Appendix A: System Specifications** 12
 - Power Requirements 12
 - Environmental Requirements 12
- LIMITED WARRANTY**

Important Safety Instructions

Always operate your DigiTrak guidance system properly to obtain accurate depth, pitch, roll, and locate points. If you have any questions about the operation of the system, please contact DCI Customer Service for assistance.

This manual is a companion to your guidance system operator's manual, which contains a more thorough list of warnings regarding the potential for serious injury and death, work slowdowns, property damage, and other hazards and warnings regarding the operation of horizontal drilling equipment. Please read and understand your system operator's manual completely before operating the equipment described in this manual.

Introduction



1. Falcon Compact Display
2. Receiver
3. Transmitters
4. Batteries, charger, and cable

Typical DigiTrak Falcon System

A DigiTrak Falcon[®] guidance system is used during horizontal directional drilling operations to locate and track a transmitter installed in the drill head. A complete system consists of a handheld receiver, transmitter, remote display on the drill rig, battery charger, rechargeable batteries with charger, and carry case.

This manual discusses only operation of the FCD remote display for use with Falcon and SE locating systems. For additional information on the other components of a DigiTrak guidance system noted above, such as batteries and charger, transmitters, and helpful information on drilling and locating, please see the corresponding DigiTrak Operator's Manual, available on the flash drive that accompanied the equipment or online at digital-control.com.

Overview



- 1. Antenna
- 2. Screen
- 3. Push button
- 4. Magnetic base

DigiTrak FCD Remote Display

General Description

The FCD remote display provides the drill rig operator with information from the receiver about the depth, orientation, and status of the transmitter. The display is powered by a DCI battery pack and is operated with a single push button.

An external telemetry antenna is supplied with your remote display to enhance signal reception up to 1000 feet with line of sight to the receiver.

The receiver's serial number is located on a label inside the battery compartment.

Installing and Removing the Battery Pack

Insert the battery into the battery compartment with the tab facing up and away from the display. The battery pack is properly installed when the tab is latched and the battery is flush with the battery compartment.



- 1. Battery tab
- 2. Battery

Remote Display with Battery Pack Installed

To remove the battery, push down on the battery tab and remove the battery from the battery compartment.

Push Button

The push button on the remote display works much like the trigger on the Falcon receiver. Pressing and releasing (clicking) the button versus holding the button briefly results in different actions.

Click	Click to open the main menu and advance through menu options.
Hold	Hold briefly and release to select menu items

Audible Tones

The remote display gives audible tones to signal power on/off, menu changes, transmitter (Tx) temperature increases, and the pass/fail status of actions.

Power On	One short beep followed by a long beep.
Power Off	Four long beeps.
Confirmation Signal	Four short beeps to confirm a successful menu selection.
Failure Signal	A failure screen is accompanied by two long beeps to indicate a problem with the menu item selected. Click to close the failure screen.
Tx Temp Warning	A beep that occurs without user interaction signifies a transmitter temperature increase.

Adjusting the Viewing Angle

The remote display's viewing angle is adjustable through a range of 180° left/right, 90° up/down, and 270° sideways about the display's center.

Up/Down - Loosen and squeeze together the two lock knobs on the back of the remote display, then adjust the display as desired and tighten the knobs. If the knobs are left loose, the display will hold its vertical position only until the knobs are squeezed together or the display is vibrated. Always tighten the knobs before drilling.

Left/Right - With the magnetic base secure, adjust the left-right viewing angle by rotating the display around the base.

Center - With the magnetic base secure, grasp the display and rotate it sideways to the desired orientation.



1. Up/Down
2. Sideways
3. Lock knobs
4. Left/Right

Remote Display View Angle Adjustments

Main Menu

Access the Main menu by clicking the button. It shows the menu options with the Remote Mode option automatically highlighted for selection. If no selection is made within three seconds, the screen returns to the default Remote Mode locating screen.

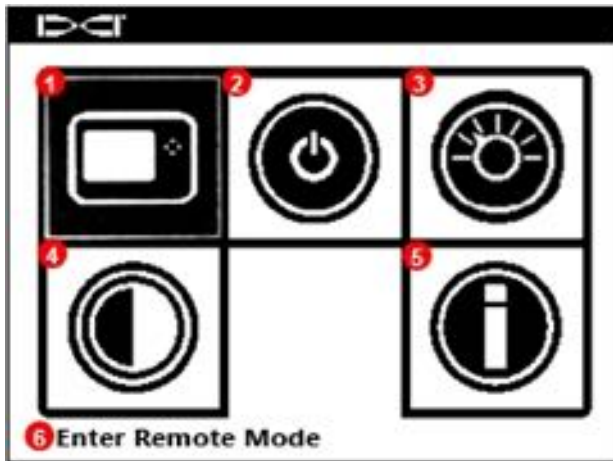

1. [Remote Mode](#) (shown highlighted)
2. [Power On/Off](#)
3. [Settings](#)
4. [Contrast Adjustment](#)
5. [System Information](#)
6. Description of highlighted option

Remote Display Main Menu

Click the button to advance between options, hold briefly and release to select a highlighted option. The main menu options are described in the following sections.

Remote Mode

Select this option to return to the Remote Mode locating screen, or wait three seconds for the screen to return automatically.



Power On/Off

Power On – Hold the button on the front of the remote display. A tone sounds and the Remote Mode locating screen appears.



Power Off – Click to open the main menu. Click again to highlight the Power Off icon, then hold until the remote display beeps three times and turns off.

Settings

Select **Settings** to change the following:

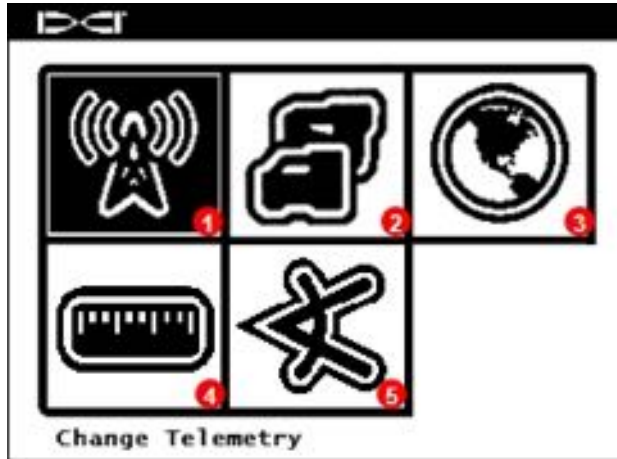

1. Telemetry channel 1-4
2. SE or Falcon F2 mode
3. Region and telemetry frequency
4. Distance and temperature units
5. Pitch units

Remote Display Settings Menu

The bottom two options are available in Falcon mode only.

As on the Main menu, click repeatedly to reach an item, then hold briefly to select. Use the same sequence to make a selection from an onscreen menu. After a few seconds of inactivity, the screen returns to the Remote Mode locating screen.

Contrast Adjustment

Contrast is easily adjusted from the Remote Mode screen by simply holding the button until the contrast is at the desired level.



Select this option to set the screen contrast in increments. Click to select the down arrow to decrease contrast or the up arrow to increase contrast. Hold the button while an arrow icon is selected to adjust the contrast one increment at a time. When the contrast is adjusted as desired, release to return to the Remote Mode screen.

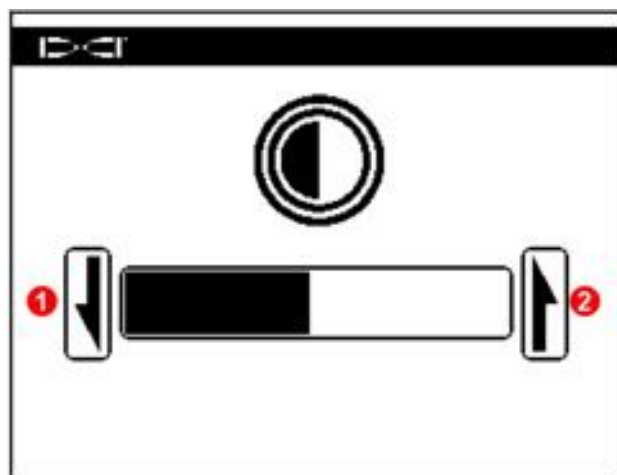

1. Down arrow decreases contrast (darkens screen)
2. Up arrow increases contrast (lightens screen)

Screen Contrast

System Information

Select this option to display system information such as the software version, serial number, and current settings.



Display Screens

Remote Mode Locating Screen

The Remote Mode locating screen is the default screen seen when the remote display turns on. It shows the transmitter pitch, roll, battery status, and temperature, as well as the display's battery status, receiver type, telemetry channel, telemetry update meter, and remote steering data (if programmed).

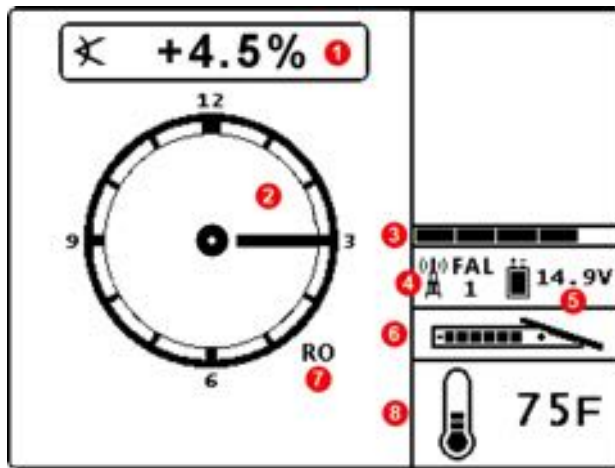

1. Transmitter pitch
2. Roll indicator
3. Telemetry update meter
4. Receiver type and telemetry channel
5. FCD battery strength
6. Transmitter battery strength (alkaline only)
7. Roll offset indicator (if roll offset is set on receiver)
8. Transmitter temperature

Remote Mode Locating Screen

The telemetry update meter displays the quality of signal being received from the receiver. If data is received less frequently, fewer bars display on the meter. When the meter is empty, no telemetry data is being received and all transmitter information will disappear.



If the meter is decreasing or low, ensure you have stable data before making steering decisions.

If the roll offset function is set on the receiver, RO displays at the bottom right of the roll indicator.

Depth Screen

Transmitter depth appears on the remote display when the receiver operator holds the trigger at the locate line (LL).

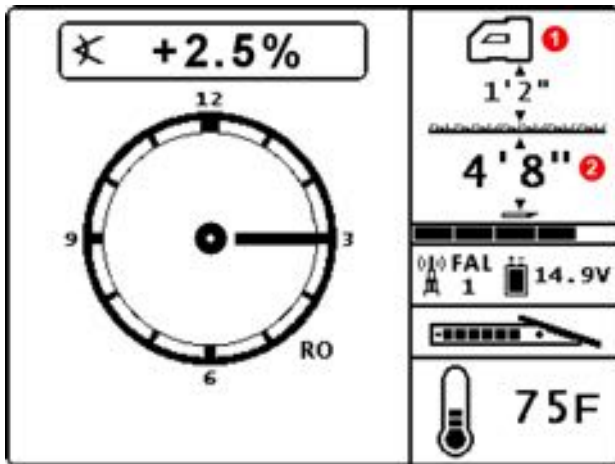

1. Height Above Ground (HAG) setting on
2. Depth of transmitter

Depth at LL with HAG On

When the Height-Above-Ground (HAG) function is enabled on the receiver, the receiver icon is shown elevated above the ground with the HAG setting displayed, as shown above; the receiver must be held the noted distance above the ground for an accurate depth reading. If a HAG value has not been programmed on the receiver, the receiver icon will display on the ground with no HAG value.

The depth will display for 10 seconds after the trigger on the receiver is released, then the display returns to the Remote Mode locating screen.

Predicted Depth Screen

The Predicted Depth screen appears when the receiver is positioned at the front locate point (FLP) with the trigger held in. Predicted depth is what the estimated depth of the transmitter will be when it passes below the receiver if the drill head remains at its current pitch.



Because both locate points appear identical to the receiver, an invalid depth prediction can be generated when the receiver is over the rear locate point (RLP). Only a reading at the front locate point (FLP) produces a valid predicted depth.

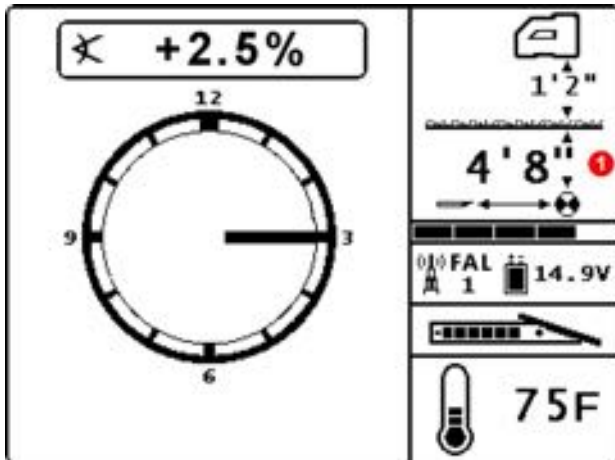

1. Predicted depth of transmitter

Predicted Depth at FLP with HAG On

When the transmitter pitch information cannot be obtained at the receiver due to range restrictions or interference, the remote display will assume the transmitter has a pitch of zero for depth and predicted depth readings. In this case, the remote display will show the transmitter pitch as:

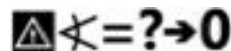

"Warning, Pitch is Unknown, Assume Zero"

Remote Steering

Instructions for setting up the receiver for using the Remote Steering feature can be found in the operator's manual for your locating system. Most of the setup for Remote Steering is done by the receiver (locator) operator. This section discusses how to use Remote Steering data on the remote display.

In general, Remote Steering should be used to maintain a bore path, not to bring a significantly off-course bore back on track. If the drill head is already significantly off course, use front and rear locate methods as described in your DigiTrak system operator's manual to get back on course.



After learning the concepts of Remote Steering, practice its use *before* using on a jobsite where time and money are at a premium. A *Look-Ahead Locating* animation is also available at www.YouTube.com/DCIKent. If you need further assistance, please contact DCI Customer Service.

Remote Steering requires a stable signal from both the transmitter and receiver.

Remote Steering will not work properly with passive interference in the vicinity of the bore.

Steering to the Target

Once Remote Steering has been enabled on the receiver, the remote display automatically enters Remote Steering mode to show steering instructions.

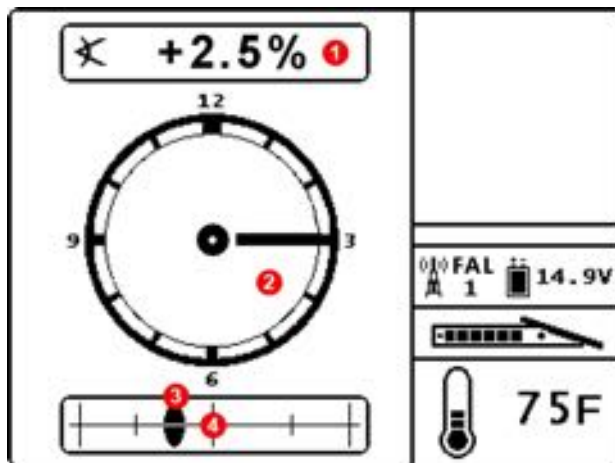

1. Transmitter pitch
2. Roll indicator
3. Left/right remote steering indicator (represents transmitter)
4. Left/right steering target (represents receiver)

Remote Steering Data on the Remote Display

The remote steering indicator on the remote display shows the projected destination of the drill head on its current path. The location of the indicator tells you whether to steer the drill head left or right. If the indicator drifts to the left, as shown above, then steer to the right. If it drifts right, steer left. The drill is on track to reach the location below the receiver when the indicator is centered on the target. Monitor the transmitter for changes in pitch.

As shown in the following example, the steering indicator will help you line up the drill head with the receiver before it reaches the target.

Note how the indicator being on the left of the receiver does not necessarily mean that the transmitter is also on the left of the receiver.

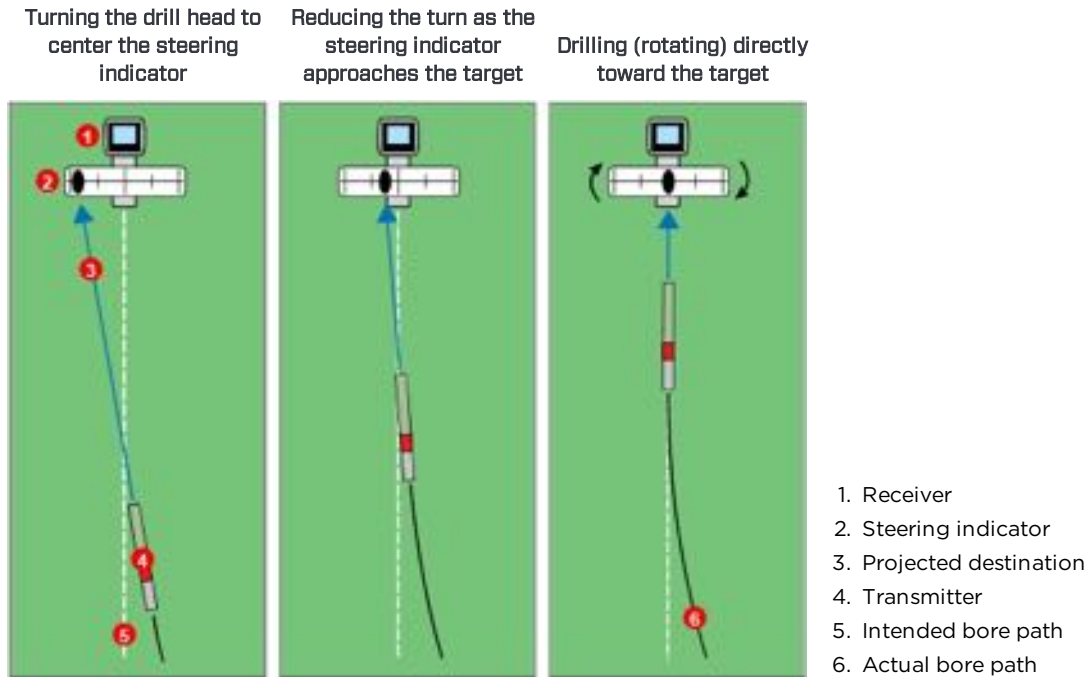

Remote Steering and the Steering Indicator, Overhead View

The left panel of the remote steering scenario above suggests that on the current heading, with no further steering corrections, the drill head will arrive to the left of the target below the receiver. However, as the drill head moves in relation to the target (center panel), the steering indicator will also move. The right panel shows the transmitter (drill head) having reached the intended bore path and drilling directly toward the target.

While drilling, monitor the steering indicator closely, make small steering adjustments, and watch and wait for the results. The closer the drill head is to the receiver, the more sensitive the steering indicator becomes. As it approaches the target, reduce the amount of the turn. When the indicator is centered on the target, the drill head is correctly positioned on the intended bore path to drill toward the target.

The steering indicator can only show steering corrections within the limits of the remote steering target (see the receiver system operator's manual for more information on Remote Steering limitations). Once the indicator has reached the edge of the target, or "pegged", drilling farther off course will not be reflected on the meter. Make the necessary steering corrections and when the steering indicator begins moving closer to the target, begin reducing the amount of the turn.

Remote steering information is only correct when the receiver is properly positioned beyond the front locate point and within the range limits of the transmitter and remote display.

Remote Steering in Interference Areas



Interference can cause inaccuracies in the measurement of depth and loss of the transmitter's pitch, roll, or heading.

In areas of passive and/or active interference, it may help to physically elevate the receiver above the ground.







Turning Remote Steering Off

When the receiver exits Remote Steering mode, the remote display automatically returns to the normal Remote Mode locating screen.

Appendix A: System Specifications

The power and environmental requirements for the DigiTrak Falcon[®] guidance system are listed below.

Power Requirements

Device (Model Number)	Operational Voltage	Operational Current
DigiTrak Falcon Compact Display (FCD)	12 - 30 V  (nominal)	150 mA max
DigiTrak SE NiMH Battery Charger (SBC)	Input 100 - 240 VAC Output 25 V  (nominal)	350 mA max 700 mA max
DigiTrak SE NiMH Battery Pack (SBP)	14.4 V  (nominal)	2.0 Ah 29 Wh max
DigiTrak F Series Battery Charger (FBC)	Input 10 - 28 V  Output 19.2 V 	5.0 A max 1.8 A max
DigiTrak F Series Lithium-Ion Battery Pack (FBP)	14.4 V  (nominal)	4.5 Ah 65 Wh max

Environmental Requirements

Device	Relative Humidity	Operating Temp.
DigiTrak Falcon Compact Display (FCD) - with NiMH Battery Pack - with Lithium Battery Pack	<90%	14 - 149 °F -4 - 140 °F
DigiTrak SE NiMH Battery Charger (SBC)	<90%	32 - 104 °F
DigiTrak SE NiMH Battery Pack (SBP)	<99%, <50 °F <95%, 50 - 95 °F <75%, 95 - 149 °F	14 - 149 °F
DigiTrak F Series Battery Charger (FBC)	<99%, 32 - 50 °F <95%, 50 - 95 °F	32 - 95 °F
DigiTrak F Series Lithium-Ion Battery Pack (FBP)	<99%, <50 °F <95%, 50 - 95 °F <75%, 95 - 140 °F	-4 - 140 °F

System working altitude: rated up to 6561 ft.

DCI Standard Warranty

DCI warrants that it will either repair or replace any product that fails to operate in conformity to DCI’s published specifications at the time of shipment due to a defect in materials or workmanship during the warranty period for that product, subject to the terms set forth below.

Category	Warranty Period
Falcon Transmitters (19” and 15”)	Three years from date of purchase or first 500 hours of use, whichever occurs first.
All Other Transmitters	Ninety days from date of purchase
Receivers, Remote Displays, Battery Chargers and Rechargeable Batteries	One year from date of purchase
Software*	One year from date of purchase
Other Accessories	Ninety days from date of purchase
Service/Repair	Ninety days from date of repair

* For software products, in lieu of the warranty set forth above, DCI warrants that it will either update any defective software to bring it into material compliance with DCI’s specifications for such software, or refund the purchase price paid for the software.

Terms

- The 3-yr/500-hr warranty period for a Falcon transmitter is conditioned on registration of the purchase with DCI within 90 days of the date of purchase. *If the customer fails to register the purchase during this time frame, the warranty period for the transmitter will instead be ninety days from date of purchase.*
- Warranty coverage for a warranty **replacement** transmitter shall tie back to the original transmitter(s) submitted for warranty coverage. For example, if a Falcon transmitter is owned for one year and used for 250 hours, the warranty coverage for the replacement will be an additional two years or an additional 250 hours of use, whichever comes first.
- “Hours of use” for purposes of the Falcon transmitter warranty means active run-time hours, as measured internally by Falcon transmitters.
- In the event of a valid warranty submission, the choice of remedy (for example, to repair or replace a defective product or, in the case of defective software, to update or refund), shall be at DCI’s sole discretion. DCI reserves the right to use remanufactured replacement parts for repairs.
- The above warranties only apply to new products purchased directly from DCI or from a DCI-authorized dealer.
- The ultimate determination of whether a product qualifies for warranty replacement shall be at DCI’s sole discretion.

Exclusions

- Transmitters that have exceeded the maximum temperature, as indicated by the system.
- Defect or damage caused by misuse, abuse, improper installation, improper storage or transport, neglect, accident, fire, flood, use of incorrect fuses, contact with high voltages or injurious substances, use of system components not manufactured or supplied by DCI, failure to follow the operator’s manual, use other than that for which the product was intended or other events beyond the control of DCI.
- Any transmitter used with an improper housing, or damage caused to a transmitter from improper installation into or retrieval from a housing.
- Damage during shipment to DCI.

Any modification, opening up, repair or attempted repair of a product, or any tampering or removal of any serial number, label or other identification of the product, will void the warranty.

DCI does not warrant or guarantee the accuracy or completeness of data generated by HDD guidance/locating systems. The accuracy or completeness of such data may be impacted by a variety of factors, including (without limitation) active or passive interference and other environmental conditions, failure to calibrate or use the device properly and other factors. DCI also does not warrant or guarantee, and disclaims liability for, the accuracy and completeness of any data generated by any external source that may be displayed on a DCI device, including (without limitation) data received from a drill rig.

DCI may make changes in design and improvements to products from time to time. DCI shall have no obligation to upgrade any previously manufactured DCI product to include any such changes.

THE FOREGOING IS THE SOLE WARRANTY FOR DCI PRODUCTS (OTHER THAN THE 5-YR/750-HR EXTENDED WARRANTY FOR FALCON 15/19" TRANSMITTERS). DCI DISCLAIMS ALL OTHER WARRANTIES, EXPRESS OR IMPLIED, INCLUDING BUT NOT LIMITED TO IMPLIED WARRANTIES OF MERCHANTABILITY AND FITNESS FOR A PARTICULAR PURPOSE, IMPLIED WARRANTY OF NON-INFRINGEMENT, AND ANY IMPLIED WARRANTY ARISING FROM COURSE OF PERFORMANCE, COURSE OF DEALING, OR USAGE OF TRADE, ALL OF WHICH ARE HEREBY DISCLAIMED.

In no event shall DCI or anyone else involved in the creation, production, sale or delivery of the DCI product ("partners") be liable for any damages arising out of the use or inability to use the DCI product, including but not limited to indirect, special, incidental, or consequential damages, or for any cover, loss of information, profit, revenue or use, based upon any claim for breach of warranty, breach of contract, negligence, strict liability, or any other legal theory, even if DCI has been advised of the possibility of such damages. In no event shall DCI or its partners' liability exceed the purchase price for the product.

This warranty is not assignable or transferable. This warranty is the entire agreement between DCI and purchaser, and may not be expanded or amended in any way other than in writing by DCI.

Product demonstrations

DCI personnel may be present at a job site to demonstrate basic usage, features, and benefits of DCI products. DCI personnel are present only to demonstrate a DCI product. DCI does NOT provide locating services or other consulting or contracting services. DCI does not assume any duty to train the user or any other person, and does not assume responsibility or liability for the locating or other work performed at a job site at which DCI personnel or equipment are or have been present.