

# 3925-HD3-14

## USER INSTRUCTIONS



Melfred Borzall housings are built to last. They are machined from high quality, 4340 alloy steel and feature contoured pockets to eliminate stress concentrations, reducing the risk of cracking. Our unique lid design allows for larger locking bolts, keeping your investment safe in tough conditions. We've also made our housings easy to use by engraving the direction of drilling and the part number for easy identification. Include the one-of-a-kind super nozzle which sprays in the off of centerline to aid steering and you've got the top of the line. Here at Melfred Borzall, we've thought of everything; so you don't have to.

**Important!** Read and understand the manufacturer's manual(s) for the directional drilling machine, locating equipment and all attachments including additional safety manual(s) provided with this tool.



**Danger!** **Do not use a pipe wrench to remove directly coupled tools.** The rod could rotate causing the device to strike you causing serious injury or death.



**Danger!** **Stay clear of rotating drill stem and tooling.** You can become caught in the rotating drill stem or tooling causing serious injury or death.



**Danger!** **Do not wear loose clothing.** Loose articles of clothing can become tangled around the drill stem or tooling causing serious injury or death.



Call before you dig—dial 811  
(USA only)  
1-888-258-0808  
(USA & Canada)

USA: (800) 558-7500  
Int'l: (805) 739-0118

**MELFRED**  
**BORZALL**

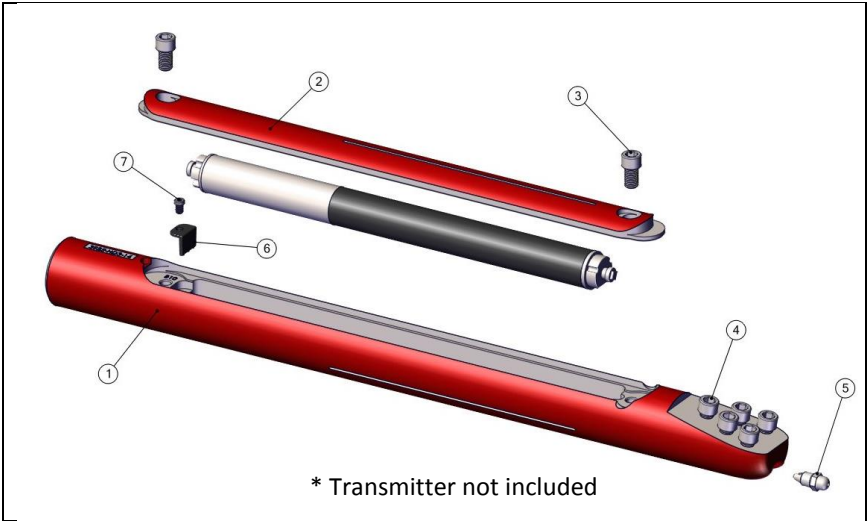

# 3925-HD3-14

## In The Box



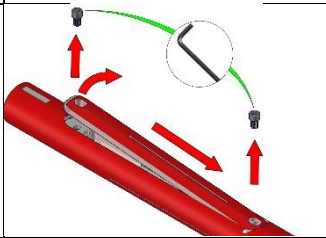

ID	Part Number	Description	REQ	SPARE
1	3925-HD3-14	Premium Sonde Housing	1	-
2	3925-HD3-CP	Sonde Pocket Cover Plate	1	-
3	SHCS12MMx20MM	M12x20mm Socket Head Cap Screw	2	2
4	SHCS12MMx25MM	M12x25mm Socket Head Cap Screw	5	-
5	1600-1712	Super Nozzle	1	-
6	86BV2-SPACER	Spacer Block for 86BV2	1	-
7	LHCS-1/4x3/8	1/4"-20 x 3/8" Low-Profile Socket Head Cap Screw	1	-
-	AW-10MM	10mm Allen Wrench	-	1
-	AW-1/8	1/8" Allen Wrench	-	1

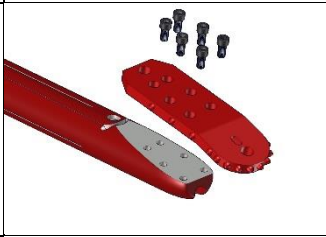
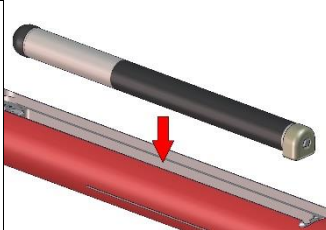
# USER INSTRUCTIONS

<p>1. Lock out the drilling machine, following the manufacturer's instructions, before doing any work to tools or drill stem.</p>	 A symbol showing a padlock with a keyhole and a curved arrow pointing to the left, indicating a lockout procedure.
<p>2. Remove the lid bolts. Then remove the lid by sliding it forward and prying up from the back.</p>	 A diagram of a red cylindrical housing with a lid. Red arrows indicate the lid being slid forward and then prying up from the back. A circular inset shows a hex key being used to remove a bolt from the lid.
<p>3a. If the <b>86BV2 transmitter</b> is used, leave the black spacer block installed.</p>	 A close-up photograph of a black spacer block installed inside a red housing. The block has a circular opening with the number '10' visible.
<p>3b. If the <b>86B transmitter</b> is used, remove the black spacer block by unscrewing the bolt holding it in place.</p>	
<p>4. Install the directional blade of your choice onto the housing steer face. Tighten each bolt to the recommended torque of 1,400 inch-pounds (165 N-m).</p>	 A diagram showing a red directional blade being attached to the housing. Several bolts are shown being inserted into the blade and tightened onto the housing.
<p>5. Install the transmitter so that the flat bottom of the front bumper is down. When properly secured, the sonde will fit snugly and resist rotation within the pocket.</p>	 A diagram showing a transmitter being inserted into a pocket in the red housing. A red arrow points down to the flat bottom of the front bumper, indicating it should be the bottom-most part of the transmitter.

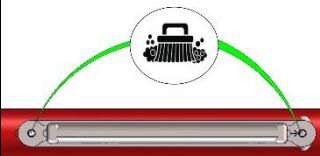
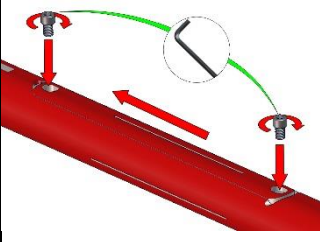
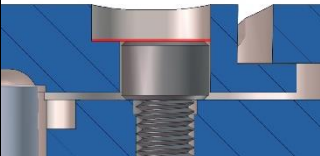
# 3925-HD3-14

<p>6. Ensure that the bolt holes are completely clear of any debris as unclean holes can prevent bolts from properly securing the lid.</p>	
<p>7. Replace the lid and install the bolts with the provided Allen Wrench. Tighten each bolt to recommended torque of 1,400 inch-pounds (165 N-m). <b>Replace bolts with new after 10 uses.</b></p>	
<p>8. Ensure that the bolts are properly seated by verifying that the bolt head is level with the machined shelf beside the hole.</p>	
<p>9. Begin your bore. Closely monitor sonde temperature to prevent overheating.</p>	
<p>10. When the bore is complete, remove the components from the housing body and clean all parts thoroughly.</p>	