

4632-HT3-13

USER INSTRUCTIONS

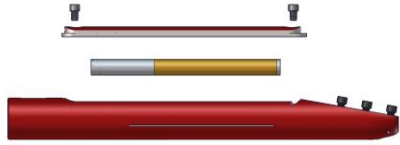

Melfred Borzall housings are built to last. They are machined from high quality, 4340 alloy steel and feature contoured pockets to eliminate stress concentrations, reducing the risk of cracking. Our unique lid design allows for larger locking bolts, keeping your investment safe in tough conditions. We've also made our housings easy to use by engraving the direction of drilling and the part number for easy identification. Include the one-of-a-kind super nozzle which sprays off of centerline to aid steering and you've got the top of the line. Here at Melfred Borzall, we've thought of everything; so you don't have to.

Important! Read and understand the manufacturer's manual(s) for the directional drilling machine, locating equipment and all attachments including additional safety manual(s) provided with this tool.



Danger! **Do not use a pipe wrench to remove directly coupled tools.** The rod could rotate causing the device to strike you causing serious injury or death.



Danger! **Stay clear of rotating drill stem and tooling.** You can become caught in the rotating drill stem or tooling causing serious injury or death.



Danger! **Do not wear loose clothing.** Loose articles of clothing can become tangled around the drill stem or tooling causing serious injury or death.



Call before you dig—dial 811
(USA only)
1-888-258-0808
(USA & Canada)

USA: (800) 558-7500
Int'l: (805) 739-0118

**MELFRED
BORZALL**

4632-HT3-13

In The Box

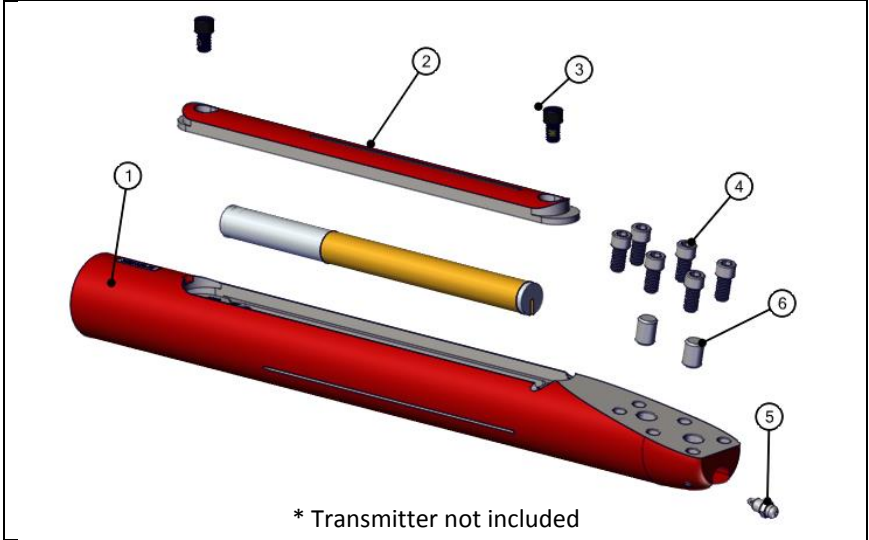

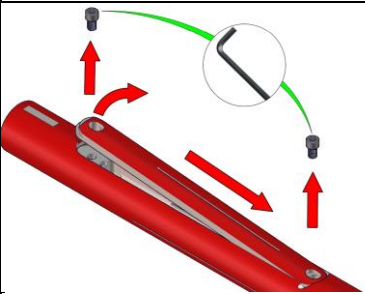
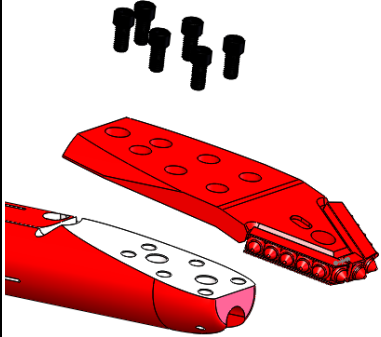
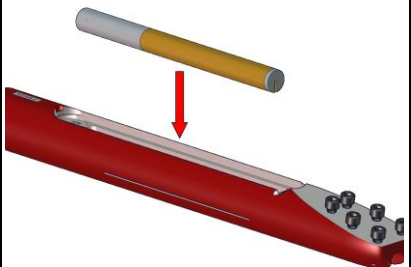

ID	Part Number	Description	REQ	SPARE
1	4632-HT3-13	Premium Sonde Housing	1	-
2	3632-HT3-13-CP	Sonde Pocket Cover Plate	1	-
3	SHCS1/2x3/4-N	1/2"-13x3/4" Socket Head Cap Screw with Nylon Patch	2	2
4	SHCS-1/2x1	1/2"-13x1" Socket Head Cap Screw	6	-
5	1600-1712	Super Nozzle	1	-
6	DP-075-100	3/4" Solid Dowel Pin, 1.00" long	2	-
-	AW-3/8	3/8" Allen Wrench	-	1

USER INSTRUCTIONS

<p>1. Lock out the drilling machine, following the manufacturer's instructions, before doing any work to tools or drill stem.</p>	 A black and white icon of a padlock with a keyhole, and a hand with a key inserted into the hole. A curved arrow above the hand indicates the direction of the key insertion.
<p>2. Remove the lid bolts. Then remove the lid by sliding it forward and prying up from the back.</p>	 A red cylindrical tool housing is shown. A green arrow points from a bolt on the top surface to a circular inset showing a hex key being used to turn the bolt. Red arrows indicate the lid being slid forward and then prying up from the back.
<p>3. Install the directional blade of your choice onto the housing steer face. Tighten each bolt to the recommended torque of 1,800 inch-pounds (200 N-m).</p>	 Four black bolts are shown above a red directional blade. Below that, the blade is shown being attached to the red housing. A white arrow points to the mating tab on the housing.
<p>4. Install the transmitter so that the indexing notch in the transmitter seats around the mating tab in the housing pocket. When properly secured, the sonde will resist rotation within the pocket.</p>	 A yellow and grey transmitter is shown above a red housing. A red arrow points down to the mating tab in the housing pocket where the transmitter will be seated.

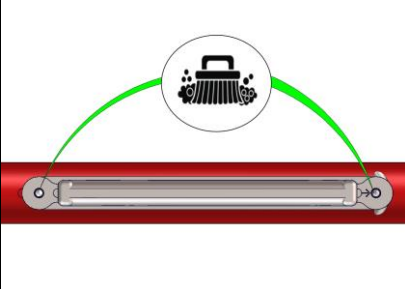
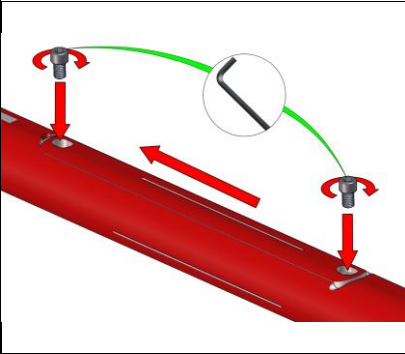
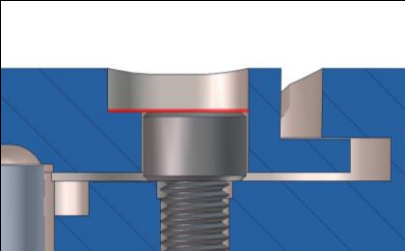
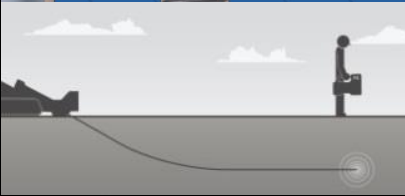
4632-HT3-13

<p>5. Ensure that the bolt holes are completely clear of any debris as unclean holes can prevent bolts from properly securing the lid.</p>	
<p>6. Replace the lid and install the bolts with the provided Allen Wrench. Tighten each bolt to recommended torque of 1,800 inch-pounds (200 N-m).</p> <p>Replace bolts with new after 10 uses.</p>	
<p>7. Ensure that the bolts are properly seated by verifying that the bolt head is level with the machined shelf beside the hole.</p>	
<p>8. Begin your bore. Closely monitor sonde temperature to prevent overheating.</p>	
<p>9. When the bore is complete, remove the components from the housing body and clean all parts thoroughly.</p>	

USER INSTRUCTIONS

Pit Bull Feature

Included with your Melfred Borzall housing is the patent pending Pit Bull design feature. This design utilizes solid dowel pins that can be inserted into the housing steer face and used with Melfred Borzall Pit Bull compatible blades (1800 series) that are available in several popular styles. This feature increases the strength of the connection between housing and blade, reducing the likelihood of broken or loosening bolts. The holes in the housing are a tight clearance fit, allowing the pins to be inserted or removed by hand. This allows the Pit Bull feature to be used when needed in harder ground conditions and to be removed when not needed.



1. Lock out the drilling machine, following the manufacturer's instructions, before doing any work to tools or drill stem.

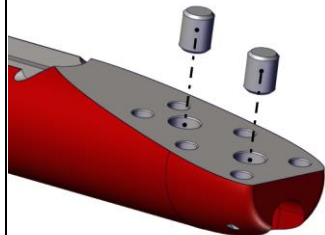

2. Insert the included dowel pins into the holes in the steering face. The pins should slide in.

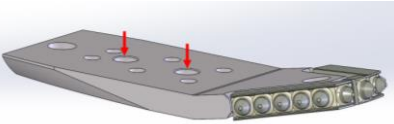
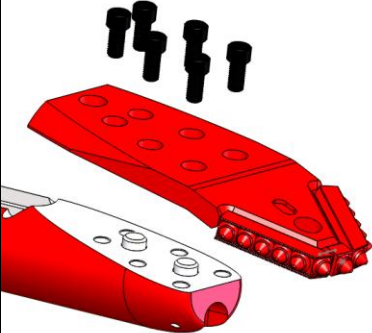

4632-HT3-13

<p>3. Install the Pit Bull compatible blade of your choice onto the housing steer face. Align the holes in the blade with pins inserted in Step 2. The holes in the blade are oversized. The blade should slide easily over the pins.</p>	 A grey metal blade with several circular holes is being aligned with two red pins that are already inserted into a housing. The blade is shown from a top-down perspective, and the housing is partially visible at the bottom right.
<p>4. Tighten each bolt to the recommended torque of 1,800 inch-pounds (200 N-m). Check that blade and steering face are flush to each other.</p>	 A red blade is being tightened onto a white housing. Four black bolts are shown being inserted into the holes of the blade. The blade is shown from a side perspective, and the housing is partially visible at the bottom left.
<p>5. When the bore is complete, remove the components from the housing body and clean all parts thoroughly.</p>	 A red stamp with the words "JOB DONE" in white, bold, capital letters. The stamp has a distressed, ink-like appearance.