

# 5932-HD4

## USER INSTRUCTIONS



Melfred Borzall housings are built to last. They are machined from high quality, US alloy steel and feature contoured pockets to eliminate stress concentrations, reducing the risk of cracking. Our unique lid design allows for a dual method of securing the lid using both larger locking bolts and a roll pin to keep your investment safe in tough conditions. Further protection is provided by our one-of-a-kind built-in sonde cushioning. We've also made our housings easy to use by engraving the direction of drilling, housing and lid part numbers for easy identification. Include redesigned dual super nozzles which jet off of centerline to aid steering and you've got the top of the line. Here at Melfred Borzall, we've thought of everything; so you don't have to.

**Important!** Read and understand the manufacturer's manual(s) for the directional drilling machine, locating equipment and all attachments including additional safety manual(s) provided with this tool.



**Danger!** **Do not use a pipe wrench to remove directly coupled tools.** The rod could rotate causing the device to strike you causing serious injury or death.



**Danger!** **Stay clear of rotating drill stem and tooling.** You can become caught in the rotating drill stem or tooling causing serious injury or death.



**Danger!** **Do not wear loose clothing.** Loose articles of clothing can become tangled around the drill stem or tooling causing serious injury or death.



# USER INSTRUCTIONS



Call before you dig – dial 811  
(USA only)  
1-888-258-0808  
(USA & Canada)

## In The Box

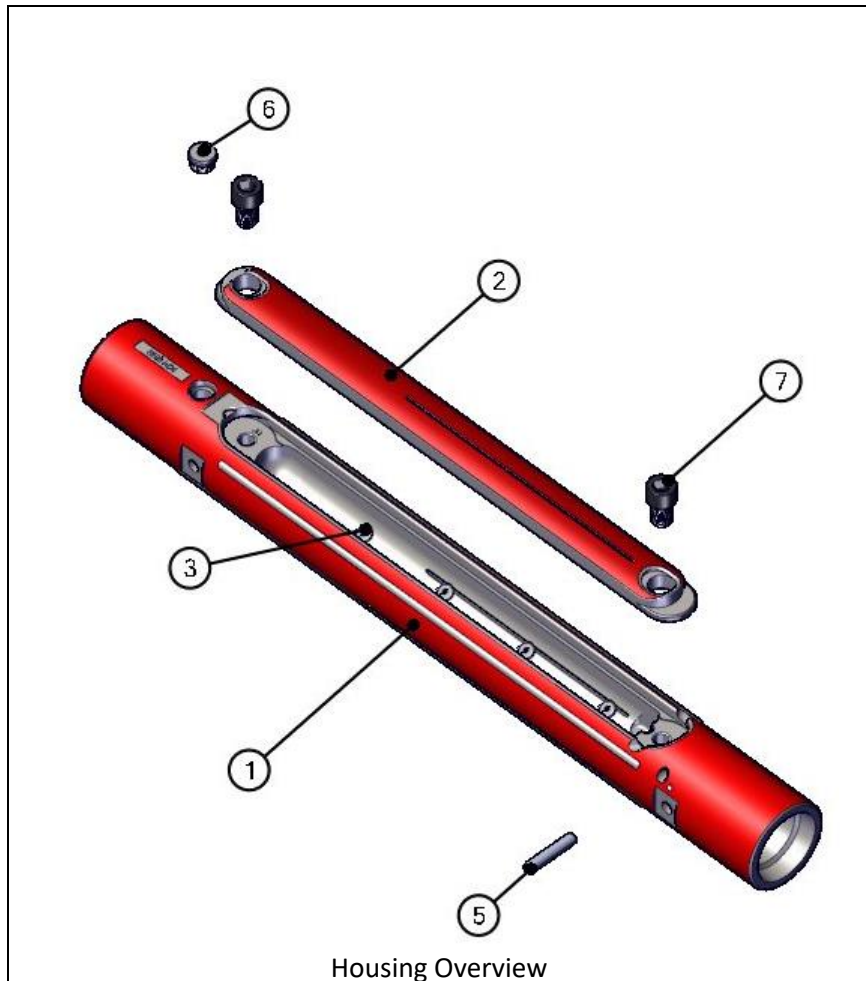

USA: (800) 558-7500  
Int'l: (805) 739-0118

**MELFRED**  
**BORZALL**

# USER INSTRUCTIONS

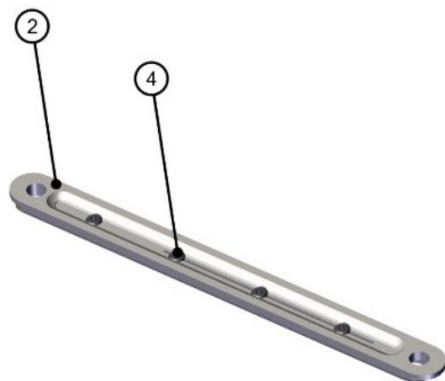

Lid and DIGI-BUMPER1-SHORT

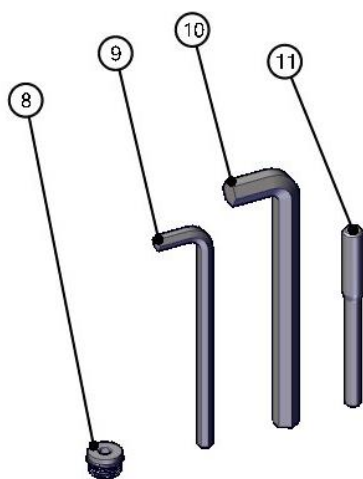

Loose parts

# USER INSTRUCTIONS

---

ID	Part Number	Description	REQ	SPARE
1	5932-HD4	Premium Sonde Housing	1	-
2	5932-HD4-CP	Sonde Pocket Cover Plate	1	-
3	DIGI-BUMPER1	Sonde Pocket Bumper	8	-
4	DIGI-BUMPER1-SHORT	Sonde Pocket Bumper, Lid	4	-
5	RP-038-200	Lid Locking Pin	1	4
6	PLUG-0.75-16	Mud Boost Plug	1	-
7	SHCS16MMX25MM	M16 Socket Head Cap Screw	2	-
8	NOZ-0.25-0.75-16	Mud Boost Nozzle	-	1
9	AW-5/16	5/16" Allen Wrench	-	1
10	AW-14MM	12MM Allen Wrench	-	1
11	PUNCH-RP-038	Roll Pin Punch	-	1

# USER INSTRUCTIONS

---

## External Features

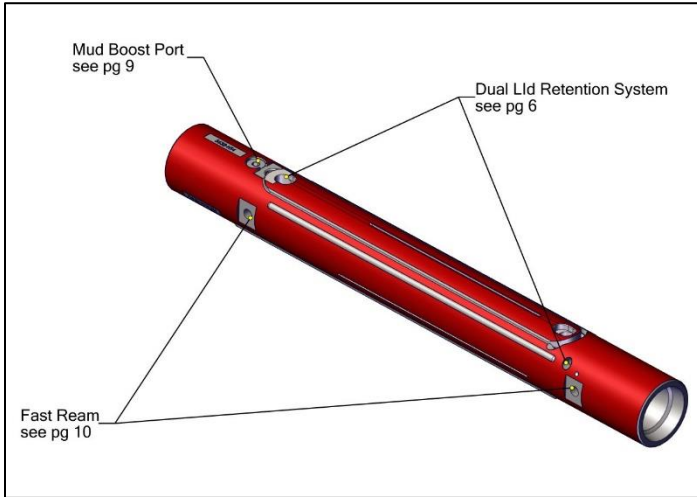

## Internal Features

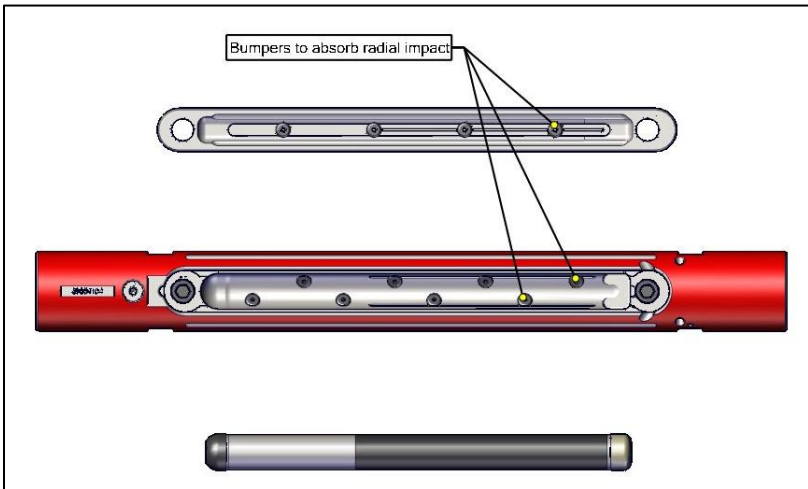

# USER INSTRUCTIONS

## General Precaution

1. Lock out the drilling machine, following the manufacturer's instructions, before doing any work to tools or drill stem.



## Dual Lid Retention

This housing utilizes both bolts and a roll pin as a redundant method of retaining the lid. The bolts do not clamp the lid but prevent it from sliding and uncovering the tabs at either end. The pin also prevents the lid from sliding and uncovering the tabs.

1. Remove Lid Locking Pin (Item 5) using PUNCH-RP-038 (Item 11) and a hammer to drive the punch.





Note: The lid pin hole also serves as a cleanout port to remove any debris that may prevent the lid from sliding forward.



2. Remove the lid bolts. Then remove the lid by sliding it forward and prying up from the back.

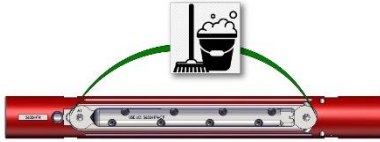

# USER INSTRUCTIONS

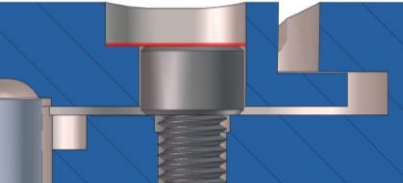
<p>3. Ensure that the bolt holes are completely clear of any debris as unclean holes can prevent bolts from properly securing the lid.</p>	
<p>4. Check that the transmitter is seated properly.</p>	
<p>5. Reinstall lid by installing forward tab into housing, rotating lid down, and sliding lid towards rear of the housing.</p>	
<p>6. Install the lid bolts (Item 7) using the provided 14MM Allen Wrench (Item 10). Tighten each bolt to the recommended torque of 238lb-ft.</p> <p><b>Replace bolts with new after 10 uses.</b></p>	
<p>7. Ensure that the bolts are properly seated by verifying that the bolt head is level with the machined shelf beside the hole.</p>	

# USER INSTRUCTIONS

8. Locate the lid pin hole. It will be just forward of the lid opening, running from the 3 o'clock to 9 o'clock position.

Align the pin with the hole and tap in with a hammer.



9. Tap pin into place using a hammer and Item 11 (PUNCH-RP-038) until pin is sub-flush on both ends.

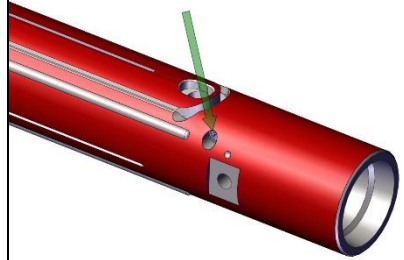



# USER INSTRUCTIONS

## Mud Boost Port

The mud boost port, located just behind the sonde lid, provides additional mud flow during pullback.

1. The housing is shipped with a plug installed (Item 6, PLUG-0.75-16). To utilize this feature, the plug must be removed and the mud boost nozzle installed (Item 8, NOZ-0.25-0.75-16).



2. Using the supplied 5/16" Allen wrench, unscrew the plug.



3. Install Item 8 (NOZ-0.25-0.75-16) by screwing into the port using the 5/16" Allen wrench.



# USER INSTRUCTIONS

## FastReam

Your Melfred Borzall housing includes the Patented FastReam feature. This allows quick attachment of Tornado-style reamer blades to enable back reaming without removing the housing and attaching a dedicated reamer.

There are several different styles and sizes of blades to use. The blades can be sized differently to progressively cut a larger hole, can be the same size, or a single blade can be used.

When using the FastReam feature, Melfred Borzall recommends using a FastReam adapter that provides additional Mud Boost ports.

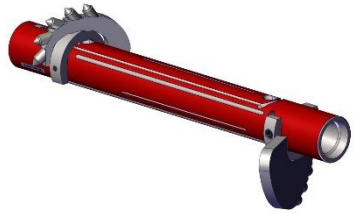

# USER INSTRUCTIONS

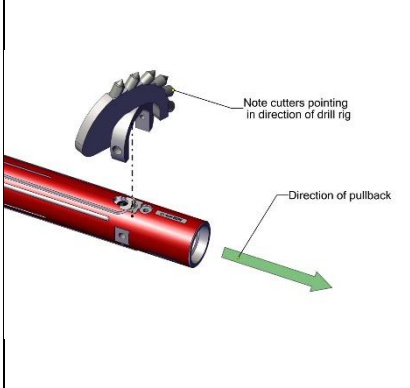
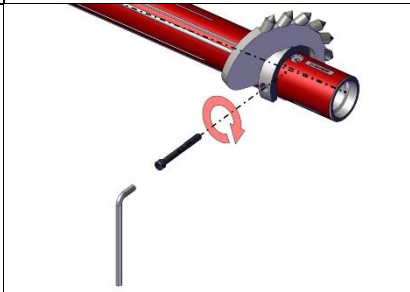
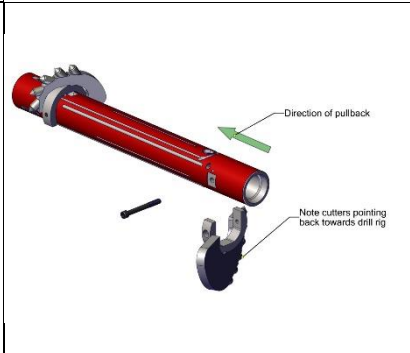
<p>1. First install rear blade. Insure cutters are facing towards the rear of the housing (back towards drill rig). Install FastReam blade from the top of the housing so that cutters are just in front of the mud boost port. The blade should fit into all three notched flats.</p>	
<p>2. Secure blade using the cross bolt through the FastReam blade and hole in housing. Use the correct size Allen wrench to tighten to 81ft-lbs.</p>	
<p>3. If desired, install the front FastReam blade. Insure cutters are facing towards the rear of the housing (back towards drill rig). Install FastReam blade from the bottom of the housing. The blade should fit into all three notched flats.</p>	

# USER INSTRUCTIONS

4. Secure blade using the cross bolt through the FastReam blade and hole in housing. Use the correct size Allen wrench to tighten to 81ft-lbs.

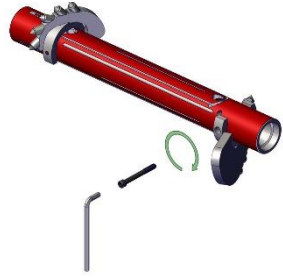

After completion of the bore, remove the components from the housing body and clean all parts thoroughly.

**JOB DONE**